



US 20150035250A1

(19) **United States**
(12) **Patent Application Publication**
Jayasuriya et al.

(10) **Pub. No.: US 2015/0035250 A1**
(43) **Pub. Date: Feb. 5, 2015**

(54) **COLLAPSIBLE BICYCLE**

Publication Classification

(71) Applicant: **Ford Global Technologies, LLC**,
Dearborn, MI (US)
(72) Inventors: **Mangala A. Jayasuriya**, Bloomfield
Hills, MI (US); **James Chih Cheng**,
Troy, MI (US); **Kristin Marie**
Schondorf, Dearborn, MI (US)
(73) Assignee: **Ford Global Technologies, LLC**,
Dearborn, MI (US)

(51) **Int. Cl.**
B62K 15/00 (2006.01)
(52) **U.S. Cl.**
CPC **B62K 15/006** (2013.01)
USPC **280/287**

(21) Appl. No.: **13/956,967**
(22) Filed: **Aug. 1, 2013**

(57) **ABSTRACT**
A motor vehicle includes a body configured to house a remov-
able frame, a spare wheel, a removable headrest, and a jack.
The frame, the spare wheel, the removable headrest, and the
jack can be assembled into a bicycle. Thus, the bicycle
includes at least one component having a dual use in a motor
vehicle.

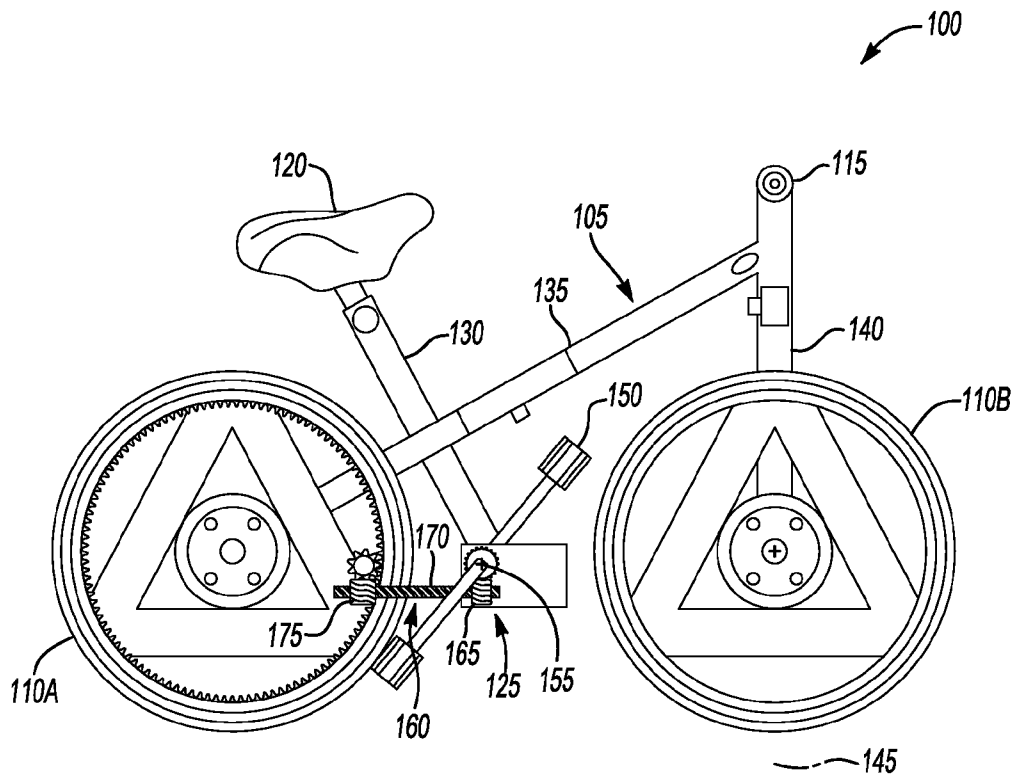

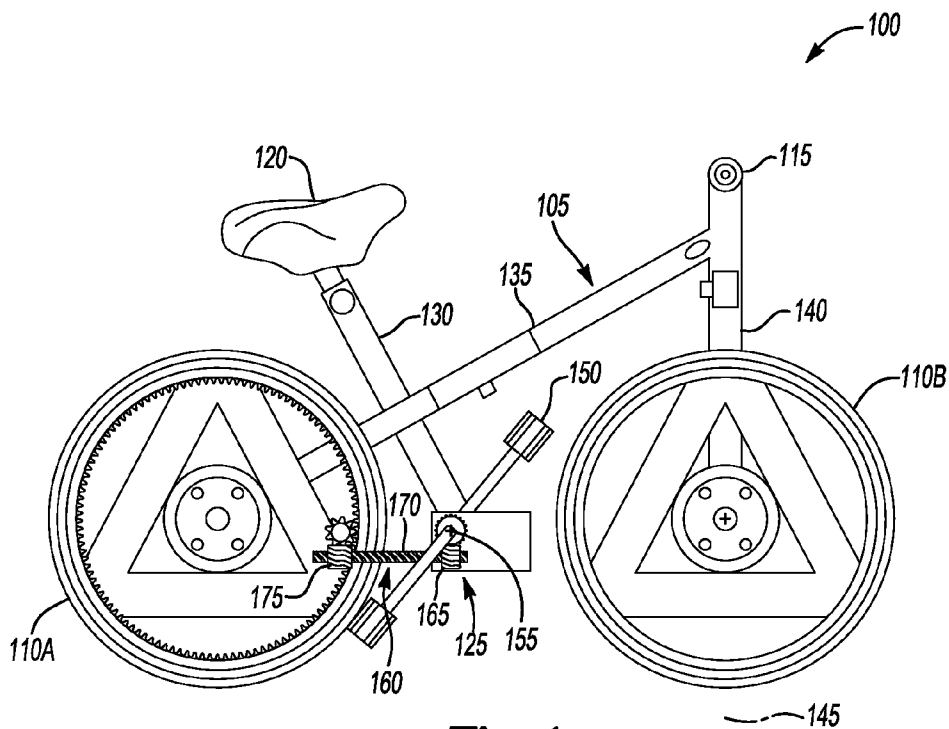

Fig-1

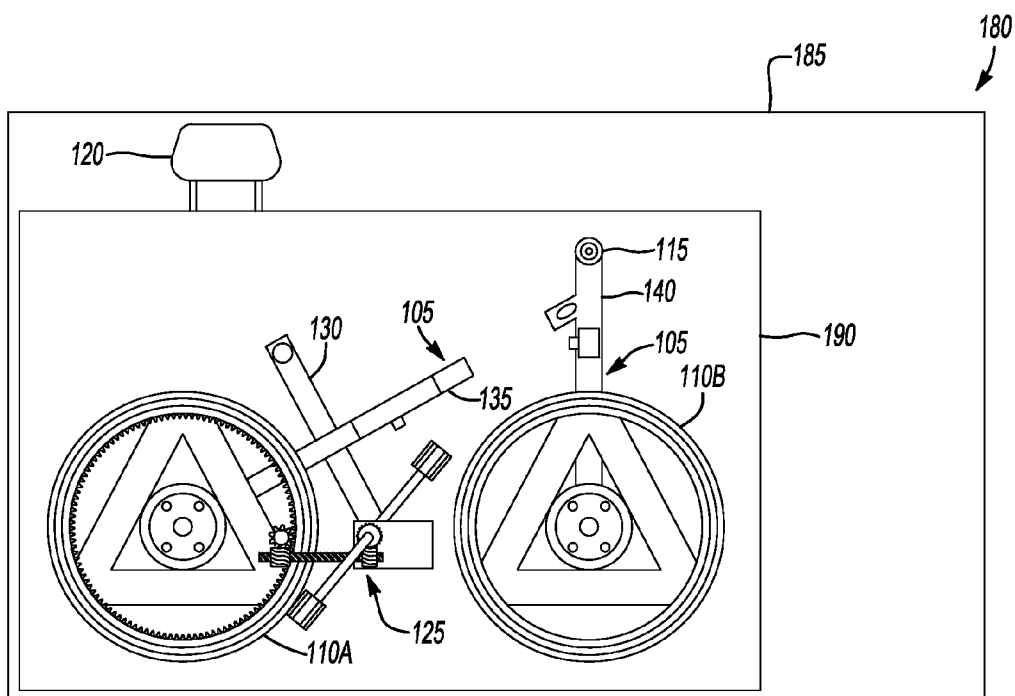

Fig-2

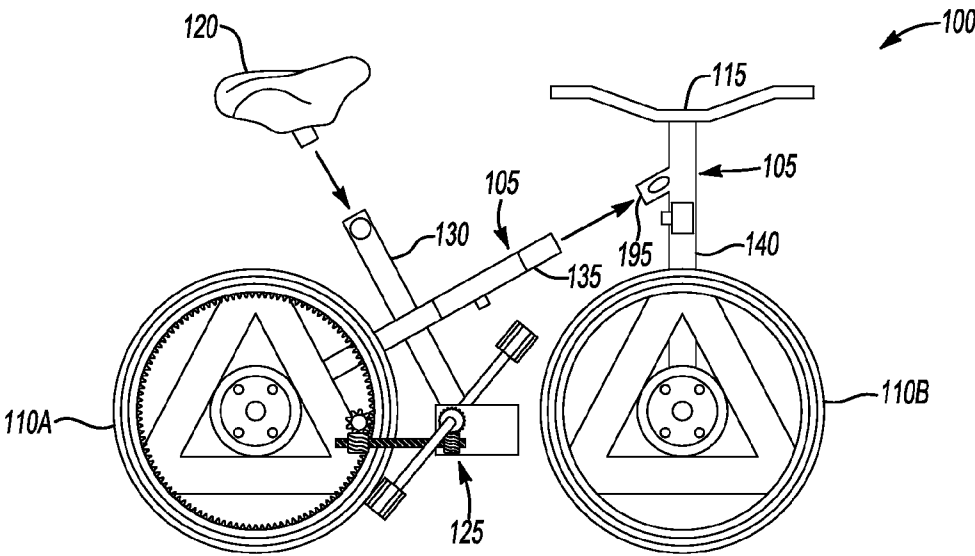

Fig-3

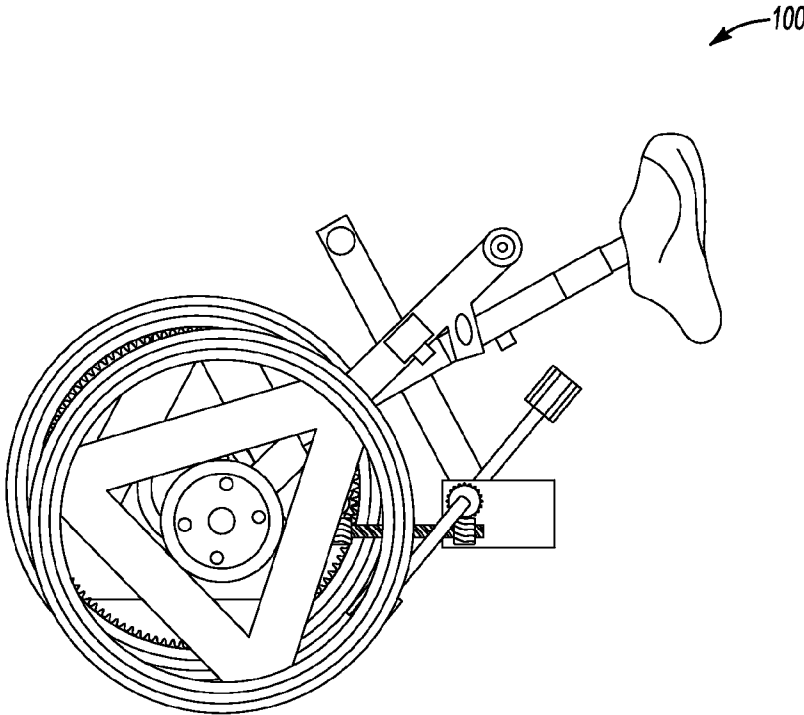

Fig-4

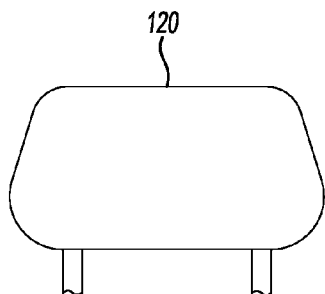

Fig-5A

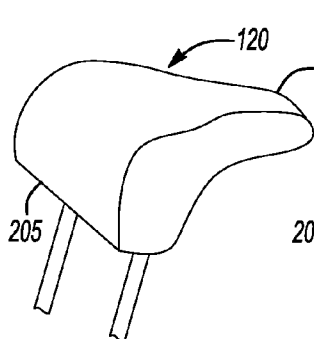

Fig-5B

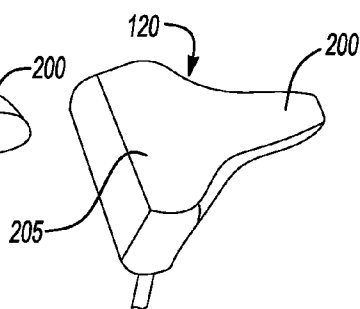

Fig-5C

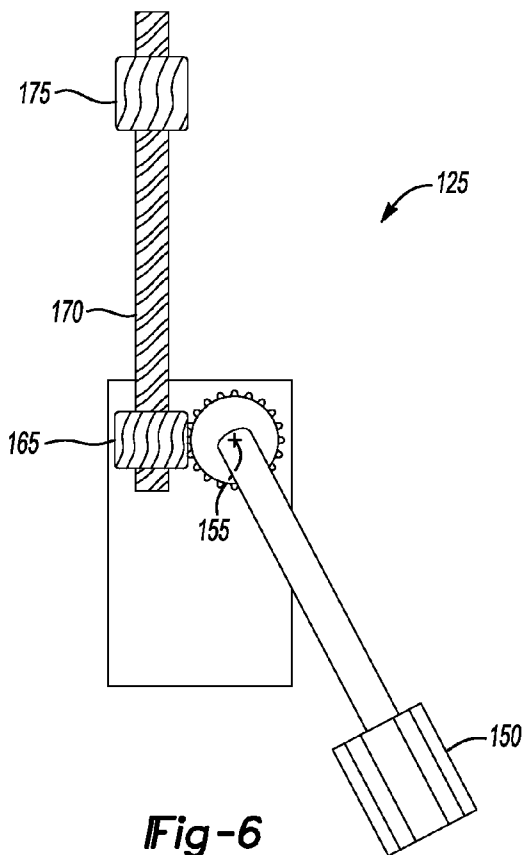

Fig-6

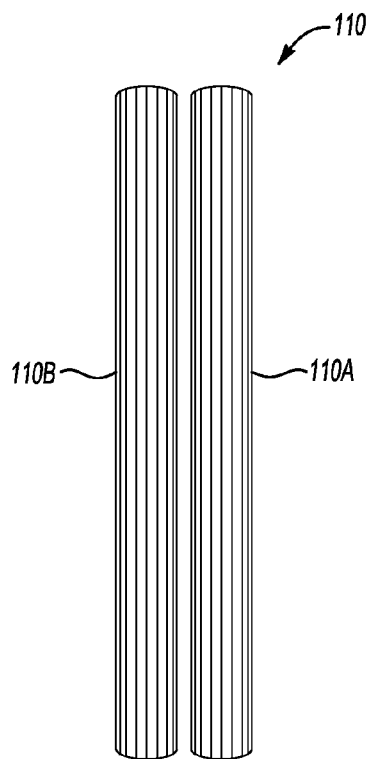

Fig-7

COLLAPSIBLE BICYCLE

BACKGROUND

[0001] Mobility in urban areas becomes increasingly difficult with population growth since increasing the infrastructure to accommodate a larger population can be difficult. For example, adding roads or increasing the size of existing roads to accommodate more passenger vehicles in urban areas can be onerous. Even if more roads were added and/or existing roads expanded, commuters to urban areas may nevertheless encounter increased pollution and parking shortages.

BRIEF DESCRIPTION OF THE DRAWINGS

- [0002] FIG. 1 illustrates an exemplary bicycle assembled from several vehicle components.
- [0003] FIG. 2 illustrates one possible arrangement of the disassembled bicycle in a vehicle.
- [0004] FIG. 3 illustrates an assembly view of the exemplary bicycle.
- [0005] FIG. 4 illustrates a collapsed view of the exemplary bicycle.
- [0006] FIGS. 5A-C illustrate different views of an exemplary headrest that may be used as the seat of the bicycle.
- [0007] FIG. 6 illustrates an exemplary jack incorporated into the bicycle.
- [0008] FIG. 7 illustrates an exemplary spare wheel that may be incorporated into the bicycle.

DETAILED DESCRIPTION

[0009] An exemplary motor vehicle includes a body that houses a removable frame, a spare wheel, a removable headrest, and a jack. The frame, the spare wheel, the removable headrest, and the jack can be assembled into a bicycle. The bicycle, therefore, includes at least one component that has a dual use in a motor vehicle.

[0010] In one possible implementation, the motor vehicle may include a body and a removable and collapsible frame disposed in the vehicle body. A spare wheel for the vehicle is formed from a first wheel removably disposed on a second wheel. A seat is located in the vehicle body and supports a removable headrest that can attach to the frame as a bicycle seat. A jack is disposed in the vehicle body and can apply a linear force when operating in a first mode and a rotational force when operating in a second mode. The jack includes a worm gear assembly that can engage at least a portion of the spare wheel to apply the rotational force to at least one of the first wheel and the second wheel when operating in the second mode. The jack further includes a pedal that can receive a user's foot, and the movement of the pedal about an axis causes the jack to apply the rotational force to at least one of the first wheel and the second wheel. Accordingly, the frame, the spare wheel, the removable headrest, and the jack can be assembled into a bicycle.

[0011] FIG. 1 illustrates an exemplary bicycle 100 formed from various vehicle components. The bicycle 100 may take many different forms and include multiple and/or alternate components and facilities. While an exemplary bicycle 100 is shown, the exemplary components illustrated in the Figures are not intended to be limiting. Indeed, additional or alternative components and/or implementations may be used.

[0012] As shown in FIG. 1, the bicycle 100 includes a frame 105, wheels 110, handlebars 115, a seat 120, and a drive mechanism 125.

[0013] The frame 105 may be configured to structurally support one or more other components of the bicycle 100 such as the wheels 110, the handlebars 115, the seat 120, and the drive mechanism 125. The frame 105 may be formed from various materials such as steel, aluminum, titanium, carbon fiber, a thermoplastic, magnesium, scandium, beryllium, bamboo, wood, or any combination of these and possibly other materials with sufficient strength to support the other components of the bicycle 100. The frame 105 may be formed from different pieces, and each piece may have a particular cross-sectional configuration. In the implementation shown in FIG. 1, the frame 105 is formed from various tubes including a seat tube 130, a down tube 135, and a head tube 140. The seat tube 130 may support the seat 120. The down tube 135 may be attached to the rear wheel 110A, the seat tube 130, and the head tube 140. The head tube 140 may support the handlebars 115 and attach to the front wheel 110B. The seat tube 130, the down tube 135, and the head tube 140 may each have a generally cylindrical configuration with a generally circular cross-section.

[0014] The wheels 110 may include a rear wheel 110A and a front wheel 110B. The rear wheel 110A may be rotatably mounted to the down tube 135 and may be configured to receive a rotational force from the drive mechanism 125, as described in greater detail below. The rotation of the rear wheel 110A may cause the bicycle 100 to move. The front wheel 110B may be rotatably mounted to the head tube 140, which as discussed above may be connected to the handlebars 115. The head tube 140 may define an axis 145, and rotation of the handlebars 115 about the axis 145 may cause the front wheel 110B to rotate about the axis 145. Thus, the front wheel 110B may be used to steer the bicycle 100. Each wheel 110 may include a rim, a tire, a hub, and spokes. In some instances, the tire may include an inflatable tube. The rear wheel 110A and the front wheel 110B may be combined to form a spare wheel 110 that may be used in a vehicle. That is, the rear wheel 110A and the front wheel 110B may be fixed to one another for use as the spare wheel 110 in a vehicle or separated for use in the bicycle 100.

[0015] The handlebars 115 may include any steering mechanism that provides the rider with the necessary leverage to steer the bicycle 100. In some instances, the handlebars 115 may allow the rider to adjust a gear ratio of the drive mechanism 125 or apply brakes (not shown). Additionally, the handlebars 115 may support at least a portion of the rider's weight. Therefore, the handlebars 115 may be formed from a relatively lightweight, stiff material such as an aluminum alloy, steel, carbon fiber, or titanium.

[0016] The seat 120 or saddle may be configured to at least partially support the rider while riding the bicycle 100. The seat 120 may be attached to the seat tube 130 when the bicycle 100 is assembled. The seat 120 may include a shell surrounded by a padding material. The shell may be formed from a plastic, such as nylon, or carbon fiber. The padding material may be formed from, e.g., a foam or gel. In some instances, the seat 120 may also serve as one of the headrests in the vehicle. When the bicycle 100 is disassembled, the seat 120 of the bicycle 100 may be placed on one of the seats in the vehicle for use as a headrest. Thus, the seat 120 may conform to any regulations concerning vehicle headrests.

[0017] The drive mechanism 125 may be configured to apply a rotational force to the wheels 110 of the bicycle 100. The drive mechanism 125 may apply the rotational force to the rear wheel 110A, the front wheel 110B, or both wheels

110. In one possible approach, the drive mechanism **125** may include a pedal assembly with pedals **150** configured to receive each of a rider's feet. The pedals **150** may rotate about an axis **155** according to forces applied to the pedal **150** by the rider. The pedals **150** may be operably connected to a worm gear assembly **160**. Thus, as the pedals **150** rotate about the axis **155**, a first gear **165** operably connected to the pedals **150** may cause a worm gear **170** to rotate according to the rotation of the pedals **150** about the axis **155**. The rotation of the worm gear **170** may cause a second gear **175** to rotate. The second gear **175** may be configured to engage, e.g., the rear wheel **110A**, resulting in rotation of the rear wheel **110A** in accordance with the rotation of the pedal **150** about the axis **155**. Accordingly, the drive mechanism **125** may generate the rotational force commensurate with the rotation of the pedals **150** about the axis **155**.

[0018] The drive mechanism **125** may be configured to operate in different modes. For instance, in a first mode, the drive mechanism **125** may be configured to apply a linear force. This way, the drive mechanism **125** may act as a jack to, e.g., at least partially lift a vehicle for maintenance such as changing a tire. In a second mode, however, the drive mechanism **125** may be configured to apply the rotational force discussed above to, e.g., the rear wheel **110A** of the bicycle **100**.

[0019] The bicycle **100** illustrated in FIG. 1 includes components that can also be used in a vehicle, such as a car, truck, sport utility vehicle, etc. For example, the rear wheel **110A** and the front wheel **110B** may be combined to form the spare wheel **110** for the vehicle. The seat **120** may be used as a headrest in the vehicle **180**. The drive mechanism **125** may be used as a jack to at least partially lift the vehicle **180** during maintenance. Moreover, the frame **105** may be collapsible so that it may be easily stored in the vehicle **180** when the bicycle **100** is not in use. Additionally, a collapsible frame **105** may allow the rider to conveniently store the bicycle **100** in an ultimate destination such as an office.

[0020] FIG. 2 illustrates an exemplary view of the disassembled bicycle **100** stored in a vehicle **180**. The vehicle **180** may include a body **185** defining various portions of the vehicle **180** such as a passenger compartment, a trunk, a cargo compartment, a hatch, or the like, and housing the components of the vehicle **180** and of the bicycle **100**. The passenger compartment may include areas of the vehicle **180** where passengers may sit. The passenger compartment may include a driver seat **120**, a passenger seat **120**, and a rear bench seat **190**. The components of the bicycle **100** may be stored behind the rear bench seat **190**. In some vehicles **180**, storing the bicycle **100** behind the rear bench seat **190** may place the bicycle **100** in the trunk. In other vehicles **180**, storing the bicycle **100** behind the rear bench seat **190** may put the bicycle **100** in the cargo compartment. Not all components of the bicycle **100** may be stored behind the rear bench seat **190** in the trunk or cargo compartment, however. In some instances, the seat **120** may act as the headrest to one of the seats in the rear bench seat **190** or another seat in the vehicle **180**. The rear wheel **110A** and the front wheel **110B** may be combined and stored in a spare tire well, which may be located in the trunk, cargo compartment, or possibly outside the vehicle **180** such as behind, in front of, or on top of the vehicle **180**. The drive mechanism **125** may be stored in the passenger compartment, trunk, or cargo compartment. For instance, the drive mechanism **125** may be stored behind the

rear bench seat **190** (as shown in FIG. 2), in the spare tire well, underneath the rear bench seat **190**, or any other place in the vehicle **180**.

[0021] In the exemplary approach illustrated in FIG. 2, the bicycle **100** is shown in two portions. A front portion includes the handlebars **115**, the front tube, and the front wheel **110B**. The rear portion includes the seat tube **130**, the down tube **135**, and the rear wheel **110A**. The rear portion as shown further includes the drive mechanism **125**. The seat **120** of the bicycle **100** is shown as the headrest of one of the seats in the rear bench seat **190**. As discussed above, at least some of these components, such as the drive mechanism **125** and wheels **110**, of the bicycle **100** may be stored elsewhere in the vehicle **180**.

[0022] FIG. 3 illustrates an assembly view of the bicycle **100** shown in FIG. 1. To assemble the bicycle **100**, the down tube **135** may be connected to the head tube **140**. A connector **195**, which may be disposed on or integrally formed with the head tube **140**, may be configured to receive the down tube **135**. The height of the bicycle **100** may be adjusted by adjusting a length of the down tube **135** and the head tube **140**. That is, both the down tube **135** and head tube **140** may have a telescoping configuration to elongate or shorten according to the desires of the rider. Lengthening the down tube **135** and the head tube **140** may make the bicycle **100** longer in width and taller in height. Conversely, shortening the down tube **135** and the head tube **140** may make the bicycle **100** shorter in both length and height. Once the down tube **135** and head tube **140** are connected, the headrest may be removed from one of the seats in the passenger compartment of the vehicle **180** and placed on the seat tube **130** to act as the seat **120** of the bicycle **100**. In some instances, the spare wheel **110** may be at least partially disassembled to separate the front wheel **110** and the rear wheel **110**. The front wheel **110B** may be attached to the head tube **140** and the rear wheel **110A** may be attached to the down tube **135**. Furthermore, the jack may be disposed on either the down tube **135** or the seat tube **130** and operably engaged with the rear wheel **110A**. As discussed above, the jack may be placed in a mode of operation consistent with generating a rotating force as opposed to a linear force.

[0023] FIG. 4 illustrates an exemplary approach where the bicycle **100** may be collapsible, e.g., to make the bicycle **100** easy to carry into a building or other area where riding a bicycle **100** is not typically permitted or desired. The bicycle **100** may be collapsed by removing the down tube **135** from the head tube **140** and removing the seat tube **130** from the down tube **135**. The rear wheel **110A** and front wheel **110B** may be aligned to reduce a footprint of the bicycle **100** and to make the bicycle **100** easier for the rider to carry.

[0024] FIGS. 5A-C illustrate different views of an exemplary headrest that may be used as the seat **120** of the bicycle **100**. FIG. 5A illustrates a front view of the exemplary headrest. The front view includes the surface of the headrest that would contact the back of a passenger's head when the headrest is placed on a seat **120** in the passenger compartment of the vehicle **180**. FIGS. 5B and 5C illustrate perspective views of the headrest of FIG. 5A. The nose **200** and support **205** portions of the seat **120** are viewable in FIGS. 5B and 5C.

[0025] FIG. 6 illustrates an exemplary jack that may serve as the drive mechanism **125** for the bicycle **100**. As discussed above, the drive mechanism **125** may include a pedal assembly with pedals **150** configured to receive each of a rider's feet. The pedals **150** may rotate about an axis **155** according to forces applied to the pedal **150** by the rider. The pedals **150**

may be operably connected to a worm gear assembly **160**. Thus, as the pedals **150** rotate about the axis **155**, a first gear **165** may cause a worm gear **170** to rotate. The rotation of the worm gear **170** may cause a second gear **175** to rotate. The second gear **175** may be configured to engage, e.g., the rear wheel **110A**, resulting in rotation of the rear wheel **110A** in accordance with the rotation of the pedal **150** about the axis **155**. Accordingly, the drive mechanism **125** may generate the rotational force commensurate with the rotation of the pedals **150** about the axis **155**.

[0026] FIG. 7 illustrates an exemplary spare tire that may be used for the wheels **110** of the bicycle **100**. As shown, the spare tire includes a rear wheel **110A** fixed to a front wheel **110B**. When used as the spare tire, the rear wheel **110A** and front wheel **110B** may remain attached. When used in the bicycle **100**, however, the rear wheel **110A** may be removed from the front wheel **110B**. When the bicycle **100** is assembled, the rear wheel **110A** may be connected to the down tube **135** and the front wheel **110B** may be connected to the head tube **140**.

[0027] With regard to the processes, systems, methods, heuristics, etc. described herein, it should be understood that, although the steps of such processes, etc. have been described as occurring according to a certain ordered sequence, such processes could be practiced with the described steps performed in an order other than the order described herein. It further should be understood that certain steps could be performed simultaneously, that other steps could be added, or that certain steps described herein could be omitted. In other words, the descriptions of processes herein are provided for the purpose of illustrating certain embodiments, and should in no way be construed so as to limit the claims.

[0028] Accordingly, it is to be understood that the above description is intended to be illustrative and not restrictive. Many embodiments and applications other than the examples provided would be apparent upon reading the above description. The scope should be determined, not with reference to the above description, but should instead be determined with reference to the appended claims, along with the full scope of equivalents to which such claims are entitled. It is anticipated and intended that future developments will occur in the technologies discussed herein, and that the disclosed systems and methods will be incorporated into such future embodiments. In sum, it should be understood that the application is capable of modification and variation.

[0029] All terms used in the claims are intended to be given their broadest reasonable constructions and their ordinary meanings as understood by those knowledgeable in the technologies described herein unless an explicit indication to the contrary is made herein. In particular, use of the singular articles such as "a," "the," "said," etc. should be read to recite one or more of the indicated elements unless a claim recites an explicit limitation to the contrary.

[0030] The Abstract of the Disclosure is provided to allow the reader to quickly ascertain the nature of the technical disclosure. It is submitted with the understanding that it will not be used to interpret or limit the scope or meaning of the claims. In addition, in the foregoing Detailed Description, it can be seen that various features are grouped together in various embodiments for the purpose of streamlining the disclosure. This method of disclosure is not to be interpreted as reflecting an intention that the claimed embodiments require more features than are expressly recited in each claim. Rather, as the following claims reflect, inventive subject mat-

ter lies in less than all features of a single disclosed embodiment. Thus the following claims are hereby incorporated into the Detailed Description, with each claim standing on its own as a separately claimed subject matter.

1. A motor vehicle comprising:
 - a body configured to house a removable frame, a spare wheel, a removable headrest, and a jack;
 - wherein the frame, the spare wheel, the removable headrest, and the jack are configured to be assembled into a bicycle.
2. The motor vehicle of claim 1, wherein the jack is configured to apply a linear force when operating in a first mode and a rotational force when operating in a second mode, wherein the jack is configured to apply the rotational force to at least a portion of the spare wheel when operating in the second mode.
3. The motor vehicle of claim 2, wherein the jack includes a worm gear assembly configured to engage at least a portion of the spare wheel when operating in the second mode.
4. The motor vehicle of claim 2, wherein the jack includes a pedal configured to receive a user's foot, wherein movement of the pedal about an axis causes the jack to apply the rotational force to at least a portion of the spare wheel when operating in the second mode.
5. The motor vehicle of claim 1, wherein the spare wheel is formed from a first wheel and a second wheel adjacent to the first wheel.
6. The motor vehicle of claim 5, wherein the first wheel is removable from the second wheel.
7. The motor vehicle of claim 5, wherein at least one of the first wheel and the second wheel is configured to rotate in accordance with a rotational force applied by the jack.
8. The motor vehicle of claim 1, wherein the headrest is configured to attach to the frame as a bicycle seat.
9. The motor vehicle of claim 1, wherein the frame is collapsible.
10. A bicycle comprising at least one component having a dual use in a motor vehicle.
11. The bicycle of claim 10, wherein the at least one component includes a vehicle jack configured to apply a linear force when operating in a first mode and a rotational force when operating in a second mode.
12. The bicycle of claim 11, wherein the jack includes a worm gear assembly configured to engage a wheel and cause the wheel to rotate when operating in the second mode.
13. The bicycle of claim 12, wherein the jack includes a pedal configured to receive a user's foot, wherein movement of the pedal about an axis causes the jack to apply the rotational force when operating in the second mode.
14. The bicycle of claim 10, wherein the at least one component includes a spare wheel formed from a first wheel and a second wheel adjacent to the first wheel.
15. The bicycle of claim 14, wherein the first wheel is removable from the second wheel.
16. The bicycle of claim 14, wherein at least one of the first wheel and the second wheel is configured to rotate in accordance with a rotational force applied by a vehicle jack.
17. The bicycle of claim 10, wherein the at least one component includes a headrest is configured to attach to a bicycle frame as a bicycle seat.
18. The bicycle of claim 17, wherein the bicycle frame is collapsible.

19. A motor vehicle comprising:
a body;
a removable frame disposed in the body, wherein the frame is collapsible;
a spare wheel formed from a first wheel disposed on a second wheel, wherein the first wheel is removable from the second wheel;
a seat disposed in the body and having a removable headrest, wherein the headrest is configured to attach to the frame as a bicycle seat; and
a jack disposed in the body and configured to apply a linear force when operating in a first mode and a rotational force when operating in a second mode, wherein the jack includes a worm gear assembly configured to engage at least a portion of the spare wheel to apply the rotational force to at least one of the first wheel and the second wheel when operating in the second mode,
wherein the jack further includes a pedal configured to receive a user's foot, wherein movement of the pedal about an axis causes the jack to apply the rotational force to at least one of the first wheel and the second wheel
wherein the frame, the spare wheel, the removable headrest, and the jack are configured to be assembled into a bicycle.

* * * * *